

ORDERING CODE

VST7DBB - 038 - B12 - B08 - 1 R 00 - A 1 - M1 *

Series

Cam ring for "P1"

Volumetric displacement cm^3/rev (in^3/rev)

014 = 43.9 (2.68)

017 = 55.0 (3.36)

020 = 66.0 (4.03)

022 = 70.3 (4.29)

024 = 81.1 (4.95)

028 = 89.9 (5.49)

031 = 99.1 (6.05)

035 = 113.4 (6.92)

038 = 120.6 (7.36)

042 = 137.5 (8.39)

Cam ring for "P2" & "P3"

Volumetric displacement cm^3/rev (in^3/rev)

B02 = 5.7 (0.35)

B03 = 9.8 (0.60)

B04 = 12.8 (0.78)

B05 = 15.9 (0.97)

B06 = 19.8 (1.21)

B07 = 22.5 (1.37)

B08 = 24.9 (1.52)

B09 = 28.0 (1.71)

B10 = 31.8 (1.94)

B11 = 34.9 (2.13)

B12 = 40.9 (2.50)

Type of shaft

1 - Keyed

2 - Keyed (SAE CC)

3 - Splined (SAE C)

4 - Splined (SAE CC)

Modifications

Mounting W/connection Variables

P1=1 1/4" P2=1" P3=3/4" S=4"	
UNC	METRIC
01	M1

Seal Class

- 1 - S1(for mineral oil)
- 4 - S4(for fire resistant fluids)
- 5 - S5(for mineral oil and fire resistant fluids)

Design Letters

Porting Combination

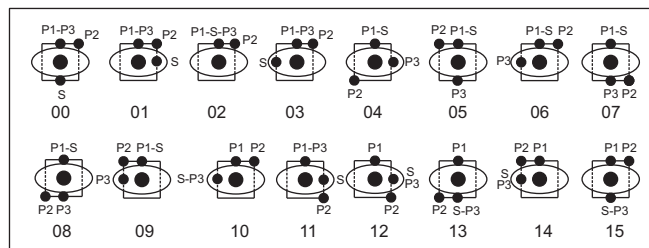

Direction of rotation (view on shaft end)

R - clockwise

L - Counter - Clockwise



INTERNAL LEAKAGE (TYPICAL)

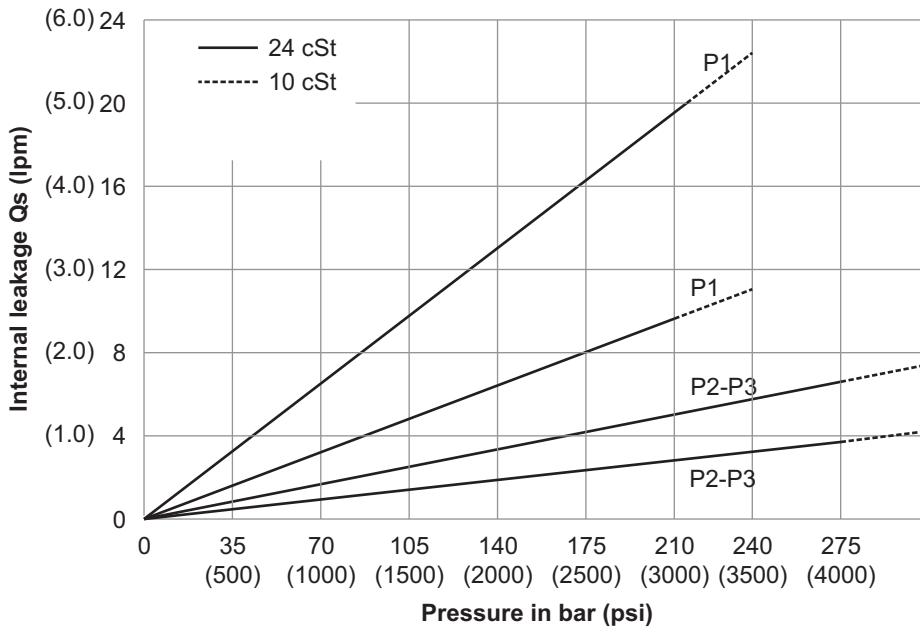

Do not operate pump more than 5 seconds at any speed or viscosity if internal leakage is more than 50% of theoretical flow. Total leakage is the sum of each section loss at its operating conditions.



NOISE LEVEL (TYPICAL) VST7DBB-038-B12-B08

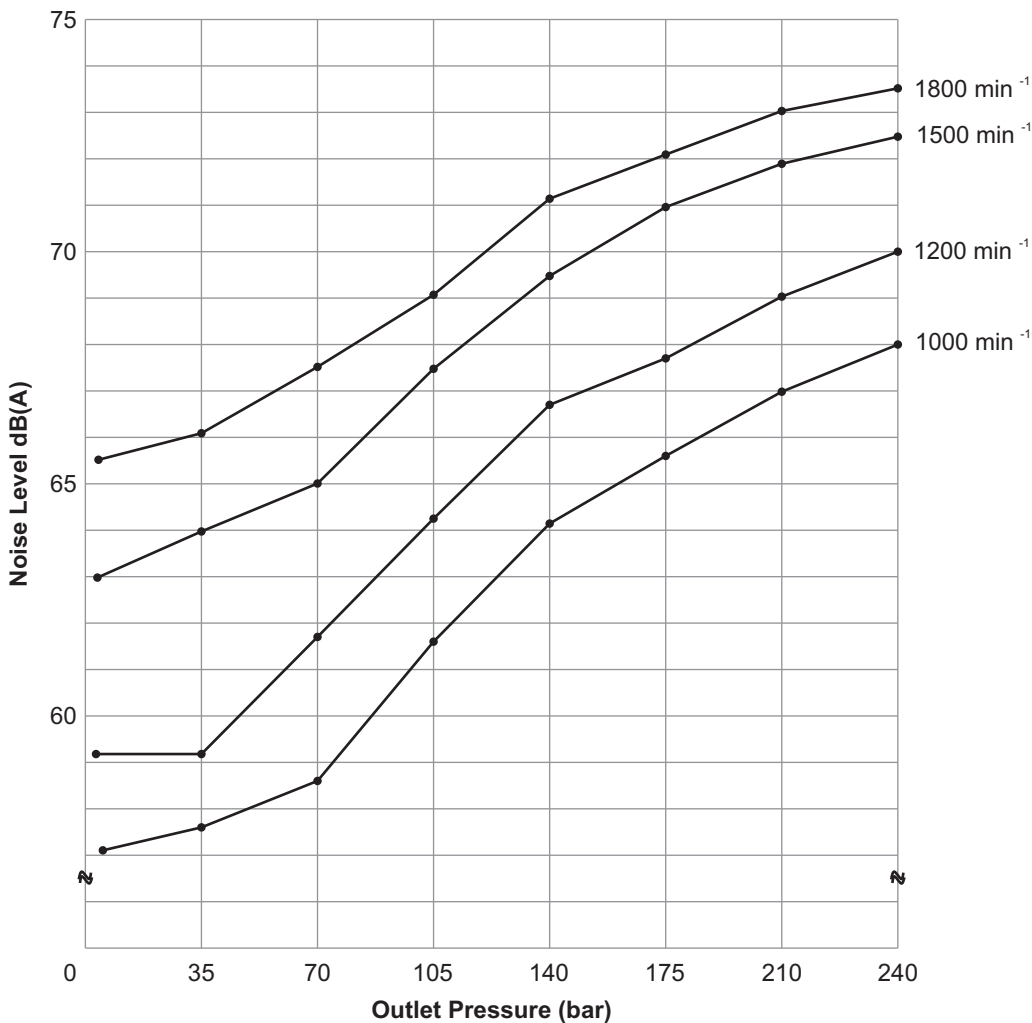

Measurement Conditions:
ISO VG32 oil at 50°C and measured 1m from rear of pump cover

INSTALLATION DRAWING
FLANGE MOUNTING

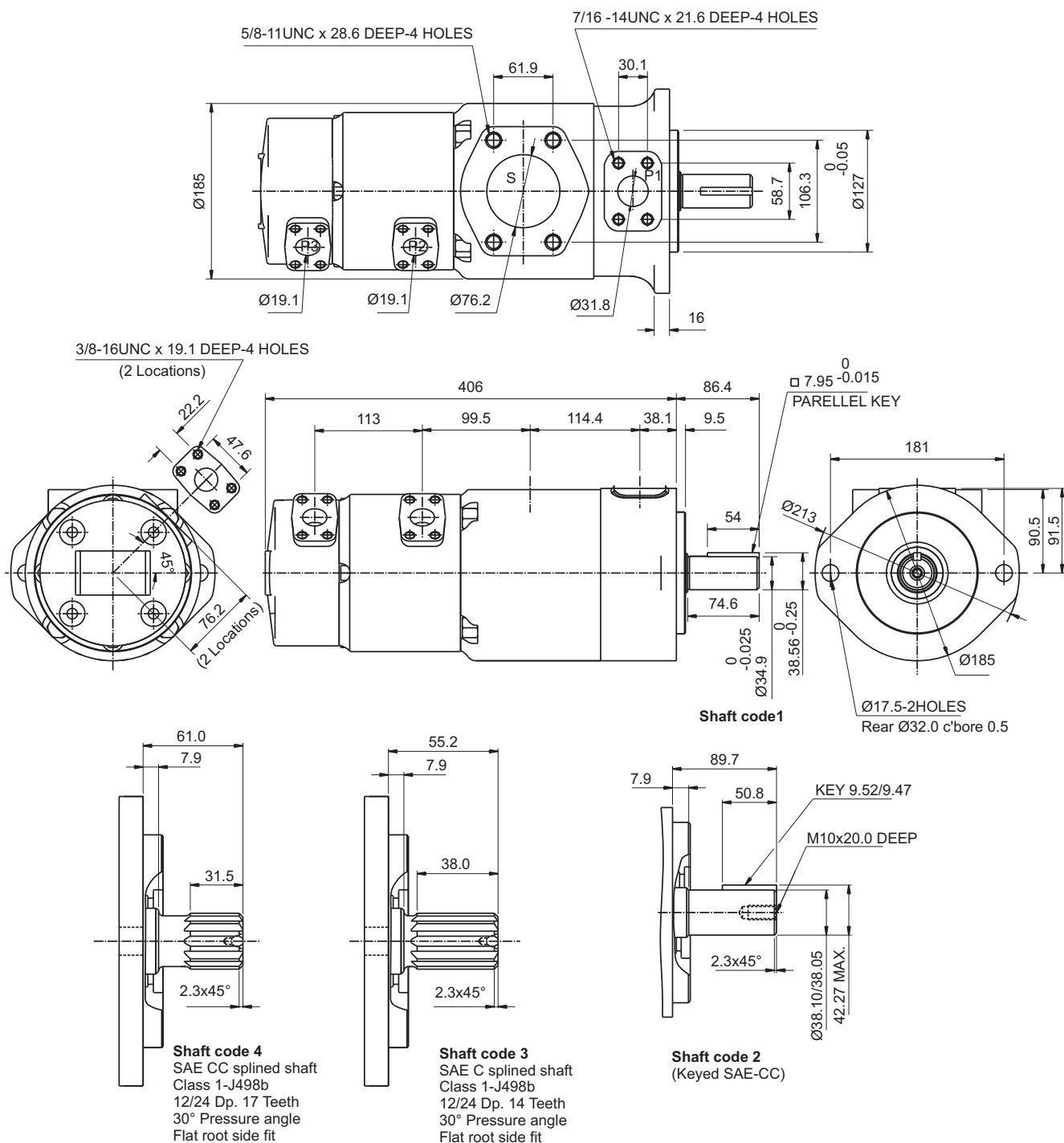

Shaft torque limits in ³ / rev x psi (ml / rev x bar)	
Shaft	Vp x p max. (P1+P2+P3)
1	38299 (43240)
2	58901 (66500)
3	54027 (61200)
4	58901 (66500)

Weight - 60.5 Kgs.

INSTALLATION DRAWING
FOOT MOUNTING

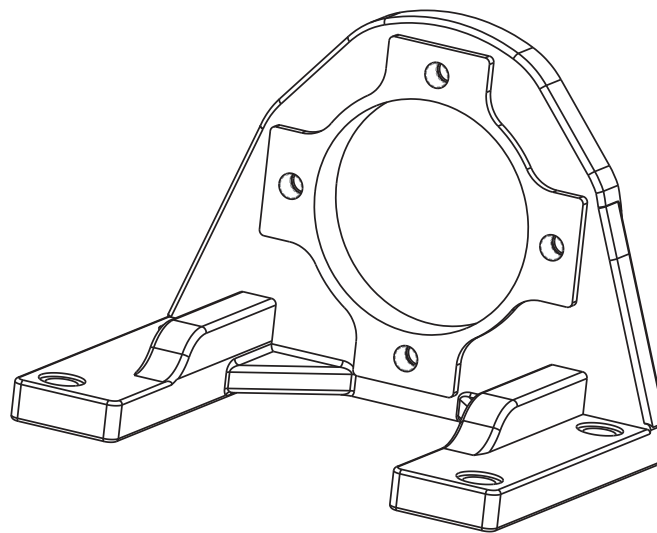
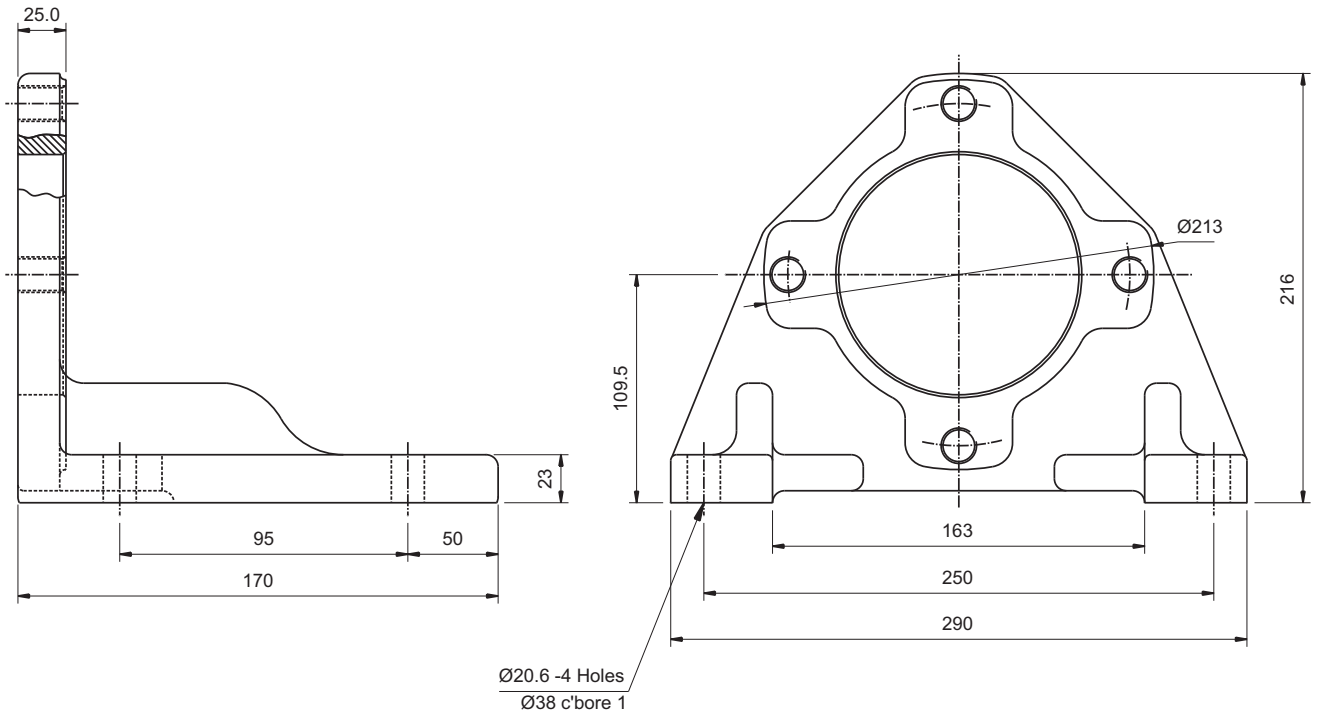

Weight-9.5 Kgs.

OPERATING CHARACTERISTICS (24 cSt)

Pressure port	Series	Volumetric Displacement Vp		Flow q (lpm) & n = 1500 rpm					
				p = 0 bar (0 psi)		p=140bar(2000psi)		p=240bar(3500psi)	
		in ³ /rev	cm ³ /rev	gpm	lpm	gpm	lpm	gpm	lpm
P1	014	2.68	43.9	18.88	71.40	16.42	62.10	14.78	55.95
	017	3.36	55.0	23.10	87.30	20.60	78.00	18.99	71.88
	020	4.03	66.0	26.19	99.00	23.73	89.70	22.08	83.58
	022	4.29	70.3	28.85	109.21	26.41	99.97	25.31	95.81
	024	4.95	81.1	31.56	119.3	29.10	110.00	27.46	103.95
	028	5.49	89.9	35.58	134.50	33.12	125.20	31.48	119.16
	031	6.05	99.1	39.00	147.50	36.53	138.10	34.89	132.07
	035	6.92	113.4	44.04	166.50	41.58	157.20	39.94	151.18
	038	7.36	120.6	47.72	180.40	45.26	171.10	43.62	165.12
	042	8.39	137.5	53.96	204.00	51.50	194.70	49.86	188.74

TP

Pressure port	Series	Volumetric Displacement Vp		Input power p & n = 1500 rpm					
				p = 7 bar (100 psi)		p = 140 bar (2000 psi)		p = 240 bar (3500 psi)	
		in ³ /rev	cm ³ /rev	hp	kw	hp	kw	hp	kw
P1	014	2.68	43.9	3.08	2.3	24.81	18.5	41.03	30.6
	017	3.36	55.0	3.35	2.5	29.77	22.2	49.62	37.0
	020	4.03	66.0	3.75	2.8	33.39	24.9	55.92	41.7
	022	4.29	70.3	4.00	2.9	36.50	27.7	63.80	46.6
	024	4.95	81.1	4.02	3.0	39.69	29.6	66.78	49.8
	028	5.49	89.9	4.29	3.2	44.52	33.2	74.96	55.9
	031	6.05	99.1	4.42	3.3	48.54	36.2	81.80	61.0
	035	6.92	113.4	4.69	3.5	54.58	40.7	92.13	68.7
	038	7.36	120.6	4.96	3.7	58.87	43.9	99.64	74.3
	042	8.39	137.5	5.36	4.0	66.25	49.4	112.24	83.7

Max, int. pressure 240 bar
 Max, cont. pressure 210 bar
 Measurement Conditions: ISO VG32 oil at 50°C

OPERATING CHARACTERISTICS (24 cSt)

Pressure port	Series	Volumetric Displacement Vp		Flow q (lpm) & n = 1500 rpm					
				p = 0 bar (0 psi)		p = 140 bar (2000 psi)		p = 240 bar (3500 psi)	
		in ³ /rev	cm ³ /rev	gpm	lpm	gpm	lpm	gpm	lpm
P2 & P3	B02	0.35	5.7	2.29	8.70	1.94	7.34	–	–
	B03	0.60	9.8	3.88	14.7	3.52	13.32	2.91	11.0
	B04	0.78	12.8	5.07	19.2	4.71	17.83	4.09	15.5
	B05	0.97	15.9	6.31	23.9	5.94	22.49	5.28	20.0
	B06	1.21	19.8	7.85	29.7	7.49	28.35	6.87	26.0
	B07	1.37	22.5	8.90	33.7	8.56	32.40	7.79	29.5
	B08	1.52	24.9	9.88	37.4	9.51	35.99	8.85	33.5
	B09	1.71	28.0	11.07	41.9	10.72	40.58	10.04	38.0
	B10	1.94	31.8	12.62	47.8	12.24	46.33	11.23	42.5
	B11	2.13	34.9	13.81	52.27	13.49	51.07	12.81	48.5
	B12	2.50	40.9	16.25	61.51	15.89	60.15	15.19	57.5

TP

Pressure port	Series	Volumetric Displacement Vp		Input power p & n = 1500 rpm					
				p = 7 bar (100 psi)		p = 140 bar (2000 psi)		p = 240 bar (3500 psi)	
		in ³ /rev	cm ³ /rev	hp	kw	hp	kw	hp	kw
P2 & P3	B02	0.35	5.7	0.62	0.46	3.08	2.30	–	–
	B03	0.60	9.8	0.71	0.53	4.96	3.70	8.35	6.23
	B04	0.78	12.8	0.78	0.58	6.37	4.75	10.77	8.03
	B05	0.97	15.9	0.86	0.64	7.78	5.80	13.18	9.83
	B06	1.21	19.8	0.95	0.71	9.49	7.08	16.40	12.23
	B07	1.37	22.5	1.01	0.75	10.74	8.01	18.28	13.63
	B08	1.52	24.9	1.06	0.79	12.00	8.95	20.42	15.23
	B09	1.71	28.0	1.14	0.85	13.39	9.99	22.84	17.03
	B10	1.94	31.8	1.23	0.92	15.13	11.28	25.25	18.83
	B11	2.13	34.9	1.30	0.97	16.69	12.45	28.46	21.23
	B12	2.50	40.9	1.45	1.08	19.51	14.55	33.29	24.83

-- Not to use because internal leakage greater than 50 of theoretical flow.
 Max, int. pressure 210 bar(3000 psi)
 Max, cont. pressure 175 bar(2500 psi), Except B02
 Measurement Conditions: ISO VG32 oil at 50°C

CONSTRUCTION

- 1. Key
- 2. Shaft
- 3. Shaft Seal
- 4. Bearing
- 5. Retaining Ring
- 6. Mounting Flange
- 7. Cartridge
- 8. Housing
- 9. Bolts
- 10. Cartridge
- 11. Port Block
- 12. Bolts
- 13. Cartridge
- 14. Endcap
- 15. Bolts

